

WARREN RUPP®

Quality System
ISO9001 Certified

Environmental
Management System
ISO14001 Certified

IDEX
IDEX CORPORATION

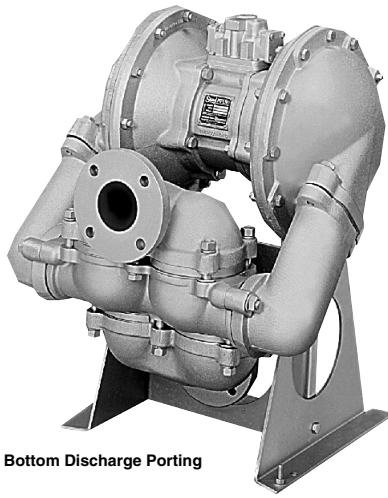

Bottom Discharge Porting

SandPIPER®

BALL VALVE SB3-A Type 3

Air-Powered Double-Diaphragm Pump

ENGINEERING, PERFORMANCE
& CONSTRUCTION DATA

INTAKE/DISCHARGE PIPE SIZE 3" 125# ASA Std. Flange	CAPACITY 0 to 260 gallons per minute (0 to 988 liters per minute)	AIR VALVE No-lube, no-stall design.	SOLIDS-HANDLING Up to 7/8" (22.2mm)	HEADS UP TO 125 psi or 289 ft. of water (8.8Kg/cm ² or 88 meters)
--	--	--	---	---

PERFORMANCE CURVES

(SandPIPER® pumps are designed to be powered **only** by compressed air)
Temperature Limit: 212°F - 100°C MAXIMUM

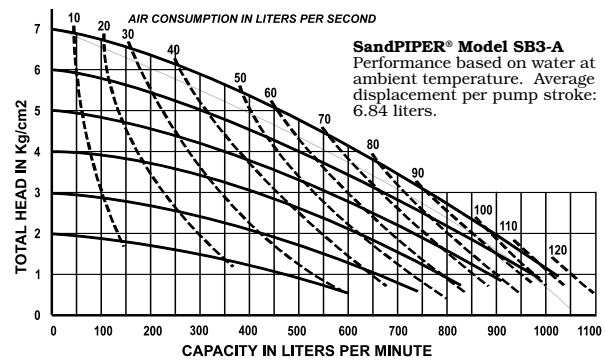
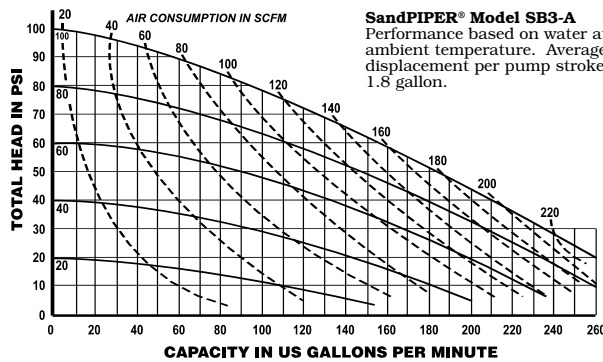

MATERIALS OF CONSTRUCTION

SB3-A Type 3	Manifold Porting			Manifold	Outer Chamber	Inner Chamber	Outer Diaphragm Plate	Inner Diaphragm Plate	Intermediate Housing	Diaphragm Rod	Valve Seat	Hard-ware	Diaphragm	Ball Valve Material	Manifold Gasket	Sealing Rings	Shipping Wt.(lbs)
	Top	Side	Bottom														
DB-3-CI			X	CI	CI	CI	PS	PS	CI	416SS	CI	PS	B	B	A	B	460
DC-3-CI			X	CI	CI	CI	PS	PS	CI	416SS	CI	PS	V	T	BG	V	460
DI-3-CI			X	CI	CI	CI	PS	PS	CI	416SS	CI	PS	I	I	A	I	460
DN-3-CI			X	CI	CI	CI	PS	PS	CI	416SS	CI	PS	N	N	A	N	460
DGN-3-CI			X	CI	CI	CI	PS	356-T6AL	CI	416SS	CI	PS	N/T	T	BG	T	460
TB-3-CI	X			CI	CI	CI	PS	PS	CI	416SS	CI	PS	B	B	A	B	440
TC-3-CI	X			CI	CI	CI	PS	PS	CI	416SS	CI	PS	V	T	BG	V	440
TI-3-CI	X			CI	CI	CI	PS	PS	CI	416SS	CI	PS	I	I	A	I	440
TN-3-CI	X			CI	CI	CI	PS	PS	CI	416SS	CI	PS	N	N	A	N	440
TGN-3-CI	X			CI	CI	CI	PS	356-T6AL	CI	416SS	CI	PS	N/T	T	BG	T	440
DB-3-SS			X	WR-S	WR-S	CI	WR-S	PS	CI	416SS	WR-S	PS	B	B	A	B	480
DC-3-SS			X	WR-S	WR-S	CI	WR-S	PS	CI	416SS	WR-S	PS	V	T	BG	V	480
DI-3-SS			X	WR-S	WR-S	CI	WR-S	PS	CI	416SS	WR-S	PS	I	I	A	I	480
DN-3-SS			X	WR-S	WR-S	CI	WR-S	PS	CI	416SS	WR-S	PS	N	N	A	N	480
DGN-3-SS			X	WR-S	WR-S	CI	WR-S	356-T6AL	CI	416SS	WR-S	PS	N/T	T	BG	T	480
TB-3-SS	X			WR-S	WR-S	CI	WR-S	PS	CI	416SS	WR-S	PS	B	B	A	B	460
TC-3-SS	X			WR-S	WR-S	CI	WR-S	PS	CI	416SS	WR-S	PS	V	T	BG	V	460
TI-3-SS	X			WR-S	WR-S	CI	WR-S	PS	CI	416SS	WR-S	PS	I	I	A	I	460
TN-3-SS	X			WR-S	WR-S	CI	WR-S	PS	CI	416SS	WR-S	PS	N	N	A	N	460
TGN-3-SS	X			WR-S	WR-S	CI	WR-S	356-T6AL	CI	416SS	WR-S	PS	N/T	T	BG	T	460

Meanings of Abbreviations:

AL = Aluminum
PS = Plated Steel
CI = Cast Iron
SS = Stainless Steel

N = Neoprene
B = Buna-N
V = Viton®

I = EPDM
T = PTFE
BG = Blue Gylon

A = Compressed Fibre
N/T = Neoprene Backup/PTFE Overlay
WR-S = Alloy Type 316 Stainless Steel

©Viton is a registered tradename of E. I. du Pont. ©Warren Rupp and SandPIPER are registered tradenames of Warren Rupp, Inc.

SB3-A BALL VALVE SandPIPER®

MATERIALS	Operating Temperatures		
	Maximum*	Minimum*	Optimum**
BUNA-N General purpose, oil-resistant. Shows good solvent, oil, water and hydraulic fluid resistance. Should not be used with highly polar solvents like acetone and MEK, ozone, chlorinated hydrocarbons and nitro hydrocarbons.	190°F 88°C	-10°F -23°C	50°F to 140°F 10°C to 60°C
EPDM Shows very good water and chemical resistance. Has poor resistance to oil and solvents, but is fair in ketones and alcohols.	212°F 100°C	-10°F -23°C	50°F to 212°F 10°C to 100°C
NEOPRENE All purpose. Resistant to vegetable oils. Generally not affected by moderate chemicals, fats, greases and many oils and solvents. Generally attacked by strong oxidizing acids, ketones, esters, nitro hydrocarbons and chlorinated aromatic hydrocarbons.	170°F 77°C	-35°F -37°C	50°F to 130°F 10°C to 54°C
PTFE Chemically inert, virtually impervious. Very few chemicals are known to chemically react with PTFE: molten alkali metals, turbulent liquid or gaseous fluorine and a few fluoro-chemicals such as chlorine trifluoride or oxygen difluoride which readily liberate free fluorine at elevated temperatures.	212°F 100°C	-35°F -37°C	50°F to 212°F 10°C to 100°C
VITON® Shows good resistance to a wide range of oils and solvents: especially all aliphatic, aromatic and halogenated hydrocarbons, acids, animal and vegetable oils. Hot water or hot aqueous solutions (over 70°F) will attack Viton®.	212°F 100°C	32°F 0°C	75°F to 212°F 24°C to 100°C
WR-S Warren Rupp Alloy Type 316 Stainless Steel equal to or exceeding ASTM specification A743 CF-8M for corrosion resistant iron chromium, iron chromium nickel, and nickel based alloy castings for general applications. Commonly referred to as 316 Stainless Steel in the pump industry.			
For specific applications, always consult a "Chemical Resistance Chart".		*Definite reduction in service life. **Minimal reduction in service life at ends of range.	

Dimensions are ± 1/8"
Figures in parenthesis = millimeters

Dimension	A	B
Std. Pump	29.3/16" (741)	8.1/8" (206)
Pulse Output	29.3/4" (756)	8.11/16" (221)

TOP PORTING

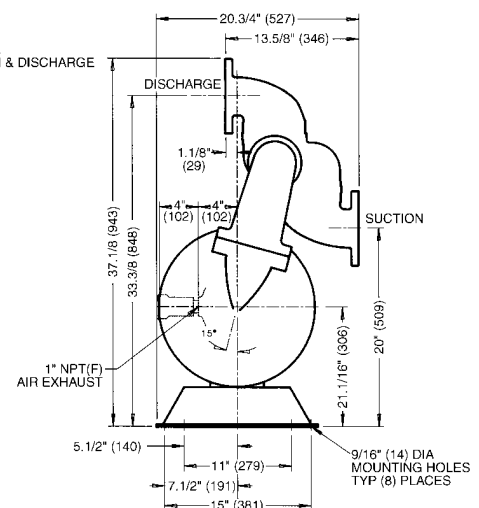
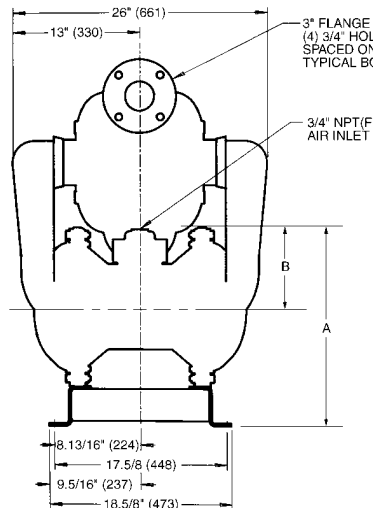

Dimension	A	B
Std. Pump	31.1/4" (794)	8.1/8" (206)
Pulse Output	31.13/16" (808)	8.11/16" (221)

BOTTOM PORTING

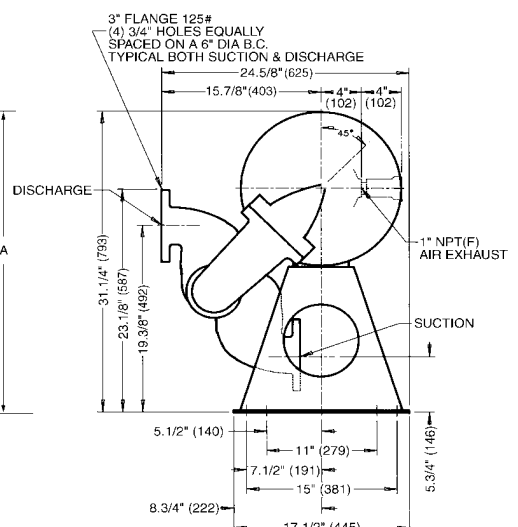
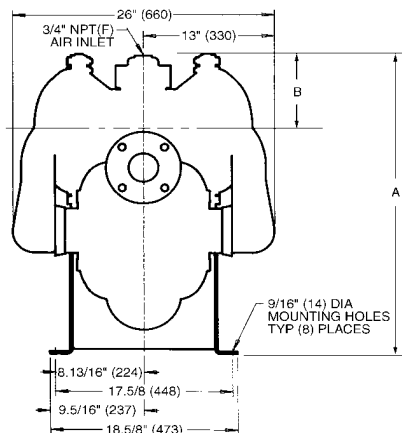

3" FLANGED SUCTION & DISCHARGE • 3/4" NPT AIR INLET PORT • 1" NPT AIR EXHAUST PORT

Copyright ©2002 Warren Rupp, Inc. All rights reserved.

Specifications are subject to improvement without notice.

©Warren Rupp and SandPIPER are registered trademarks of Warren Rupp, Inc.