

WARREN RUPP®

Quality System
ISO9001 Certified

Environmental Management System
ISO14001 Certified

IDEX
IDEX CORPORATION

SERVICE & OPERATING MANUAL and REPAIR PARTS LIST

LIQUID LEVEL CONTROL

Model 032-036-000

Warren Rupp's float actuated air valve and liquid level control provides all pneumatic operation. Especially useful in sumping and liquid transfer situations, the float actuated switch opens and closes air supply to the pump for positive ON-OFF response.

Model 032-036-000 offers:

- Completely automatic operation.
- Easy, low-cost installation. The control is plumbed as part of the piping system.
- All pneumatic operation – no electrical connections.
- Versatility. One control can be installed to handle sumping and tank filling/transfer.
- For sumping operations, the pump is started at a high liquid level, and stopped at a low liquid level. For tank filling and transfer, the pump is started at a low liquid level and stopped at a high liquid level. It's completely adjustable to any liquid level operating range. It will adjust from a few inches to approximately nine feet.
- Long life operation. Corrosion-resistant wetted parts.
- High capacity air valve. Accommodates air flow requirements up to 125 cfm, with a pressure drop less than 10 psi.

HOW IT WORKS:

This Warren Rupp liquid level control operates entirely by mechanical and pneumatic means. A float-operated air pilot valve controls the opening and closing of an air valve. It admits or exhausts air through a special regulator to turn an air-operated pump on or off.

INSTALLATION:

The line air valve and air pilot valve are preassembled on bracket and ready for mounting to 1½" (3.81 cm) standard pipe.

Unit is ready as received for standard (high level on—low level off) operation. For reverse operation (low level on—high level off), remove bracket (item

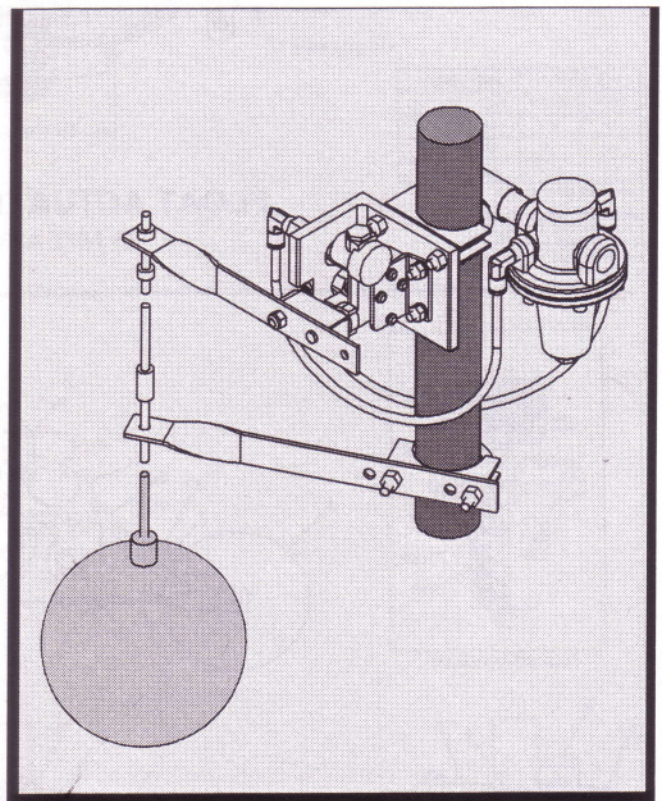

#1) from pilot valve by removing hex nut (item #12). Install bracket opposite direction from position shown and action is reversed.

Install float and rod as shown and mount rod guide bracket below control as required. A minimum of 10 PSI (.6895 Bars) air pressure is recommended for operation of liquid level control.

Air In and Air Out are noted on the regulator.

NOTE:

Important — A minimum of 8 PSI, created through pump application, must exist for the float valve to work.

LIQUID LEVEL CONTROL 032-036-000

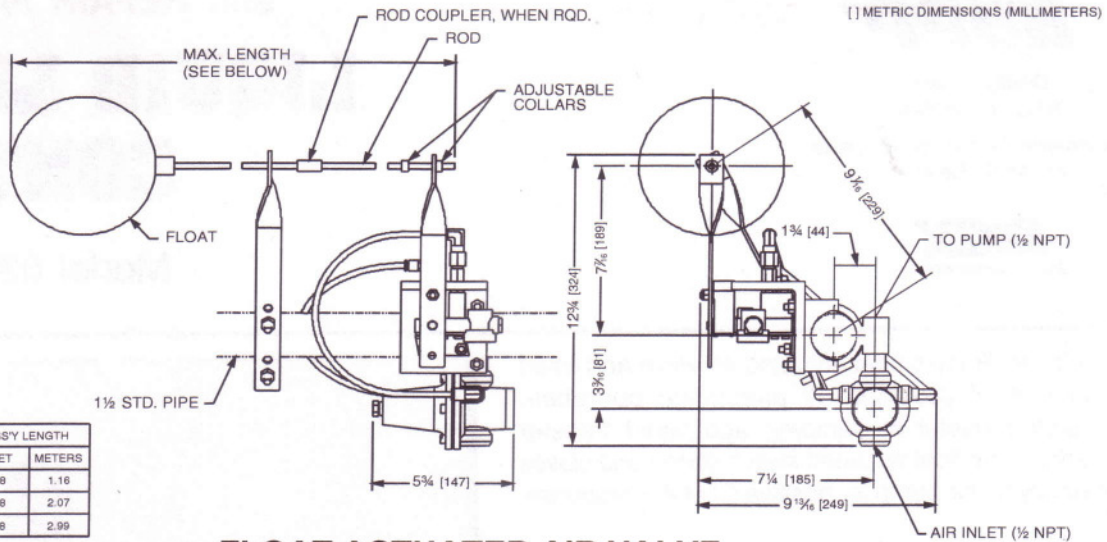

ROD LENGTH		ASSY LENGTH	
FEET	METERS	FEET	METERS
3.0	.914	3.8	1.16
6.0	1.83	6.8	2.07
9.0	2.74	9.8	2.99

* MAX. ROD LENGTH

NOTE: RODS ARE SUPPLIED IN 3 FT. [91M] LENGTHS. THE FLOAT SUPPLIED IS 6 IN. [152MM] IN DIAMETER. MINIMUM FLOAT TRAVEL=11"

FLOAT ACTUATED AIR VALVE 1/2 NPT AIR PORTS

5 PSI (0.35 Kg/Cm²) MIN. AIR PRESSURE
125 PSI (8.8 Kg/Cm²) MAX. AIR PRESSURE

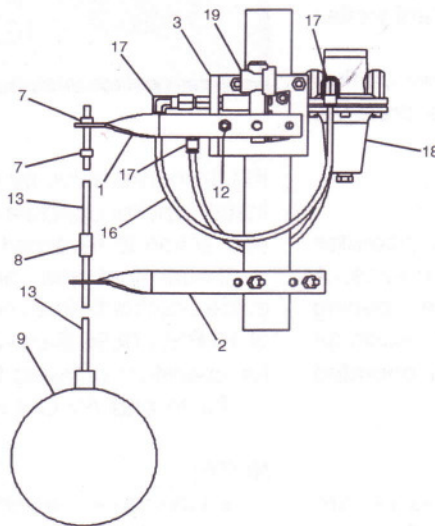
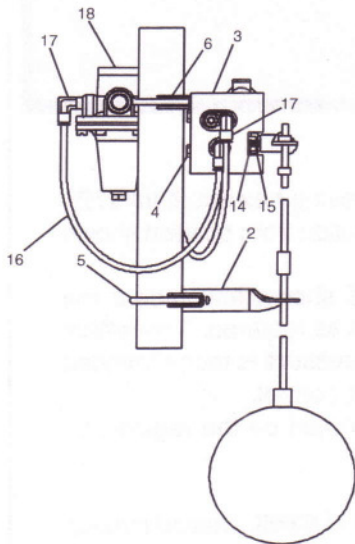
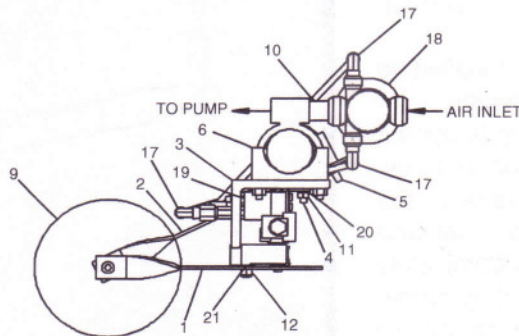
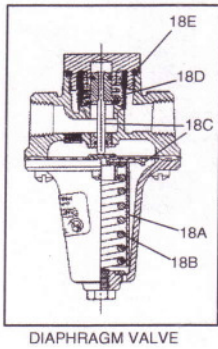

REPAIR PARTS LIST

ITEM	PART NO	DESCRIPTION	QTY
1	115-024-330	BRACKET, FLOAT ROD	1
2	115-150-330	BRACKET, FLOAT ROD	1
3	115-151-330	BRACKET, VALVE	1
4	170-043-330	CAPSCREW, HEX HD	2
5	200-010-330	CLAMP, U-BOLT	1
6	200-011-330	CLAMP, ASSEMBLY	1
7	220-003-115	COLLAR, SET SCREW	2
8	255-005-114	COUPLING, RIGID	1
9	345-001-115	FLOAT	1
10	538-006-335	NIPPLE, PIPE	1
11	545-003-330	NUT, HEX	2
12	547-003-330	NUT, ELASTIC STOP	1
13	685-015-114	ROD, TABULATED	2
14	685-016-330	ROD, DETENT	1
15	780-015-115	SPRING, COMPRESSION	1
16	860-049-550	TUBE, POLYETHYLENE	2
17	866-063-000	FITTING, TUBE, 90° ELBOW	4
18	893-024-000	VALVE, DIAPHRAGM	1
18A	860-015-080	TUBE, STOP	1
18B	780-014-080	SPRING, COMPRESSION	1
18C	RK118A	SERVICE KIT	1
18D			
18E			
19	893-092-000	VALVE, FLOAT	1
20	900-001-330	WASHER, LOCK, 1/4	2
21	901-002-330	WASHER, FLAT, 1/4	1

PRINTED IN U.S.A.

Copyright ©2006 Warren Rupp, Inc. All rights reserved.

WARREN RUPP®, INC., A Unit of IDEX Corporation • 800 North Main St. • P.O. Box 1568 • Mansfield, Ohio 44901-1568 • 419-524-8388 • Fax 419-522-7867